



GO BEYOND

ENGINEWISE

## FUEL INJECTOR & SUPPORT ASSEMBLY - NEW REPAIR REPAIR 10 - FAIRING WELD JOINT CRACK WELD REPAIR

Pratt & Whitney has developed a new PW4000-94"/100" Fuel Injector and Support Assembly fairing weld joint crack weld repair (Repair 10) to increase overall yield and reduce total cost of ownership. The new repair restores cracks on the fairing weld joints and provides an estimated 30% reduction in scrapped parts.

### SPECIFICS

P&W Engine Manual Ref: N/A  
Model: [PW 4000 -94/-100 MODEL](#)  
ATA#: [73-11-16](#)  
SB Ref: N/A

### AVAILABILITY

This repair is available from 5 May 2020 and will be applicable for the following part numbers:

51J397  
51J398

### BENEFITS

Increase overall yield by an estimated 30%  
Reduce cost of ownership to customer

### PART REFERENCE

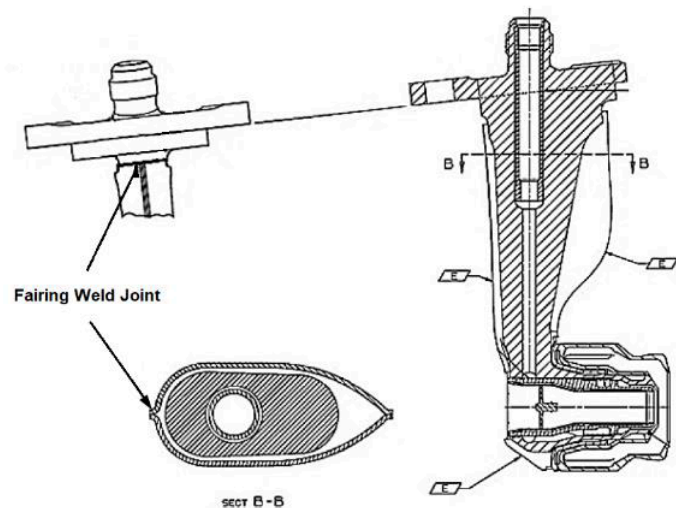

Figure 01: Fairing weld joints

Component Aerospace Singapore (CAS)  
10 Loyang Lane, Singapore 508916

Ivan Wan - Aftermarket Sales Manager  
Tel: +886 2 27190395 / Mobile: +886 933 923963  
Email: [ivan.wan@prattwhitney.com](mailto:ivan.wan@prattwhitney.com)